



Ben Kehe

MOTION PICTURE PROJECTION SERVICES, INC.

14934 East 13th Street
Tulsa, OK 74108-4534
Phone: 918-906-3715
Email: mppsinc@aol.com

**R.C.A. TELECINE 35MM PROJECTOR MODEL BX-90
RESPECTFULLY PRESENTED TO THE
EARLY TELEVISION FOUNDATION MUSEUM
BY
BEN & CATHERINE KEHE
Fall of 2025**

Carl Brenkert, President/Inventor of Brenkert 35mm Motion Picture Projectors manufactured some of the most robust and reliable 35mm motion picture projectors that were utilized in commercial movie theatres.

On July 1, 1945, R.C.A. purchased the Brenkert Light Projection Company and continued manufacture of the projection machines and carbon arc lamphouses.

This display consists of a fully restored R.C.A./Brenkert BX-90, 35mm projector head. The remainder of the telecine system and its installation and operation is shown within the attached detailed pages.

It is interesting to note the difference between this 35mm projector and the basic same projector that was utilized in commercial movie theatres. In the theatre, the film was projected at 24 frames per second.

R.C.A. modified this projector to show 35mm film to make the television camera think it was seeing film at the television rate of 30 frames per second even though the projector was still showing 24 frames per second.

>>>PLEASE ENJOY THIS DISPLAY AND THE ATTACHED PAPER.<<<

*Sales • Installation • Service • Rentals
35mm and 70mm Projection and Sound Equipment
Digital Cinema Equipment
Representing Major Manufacturers of
Projection and Sound Equipment*

**TELEVISION
35MM
PROJECTOR**

TYPE TP-35B

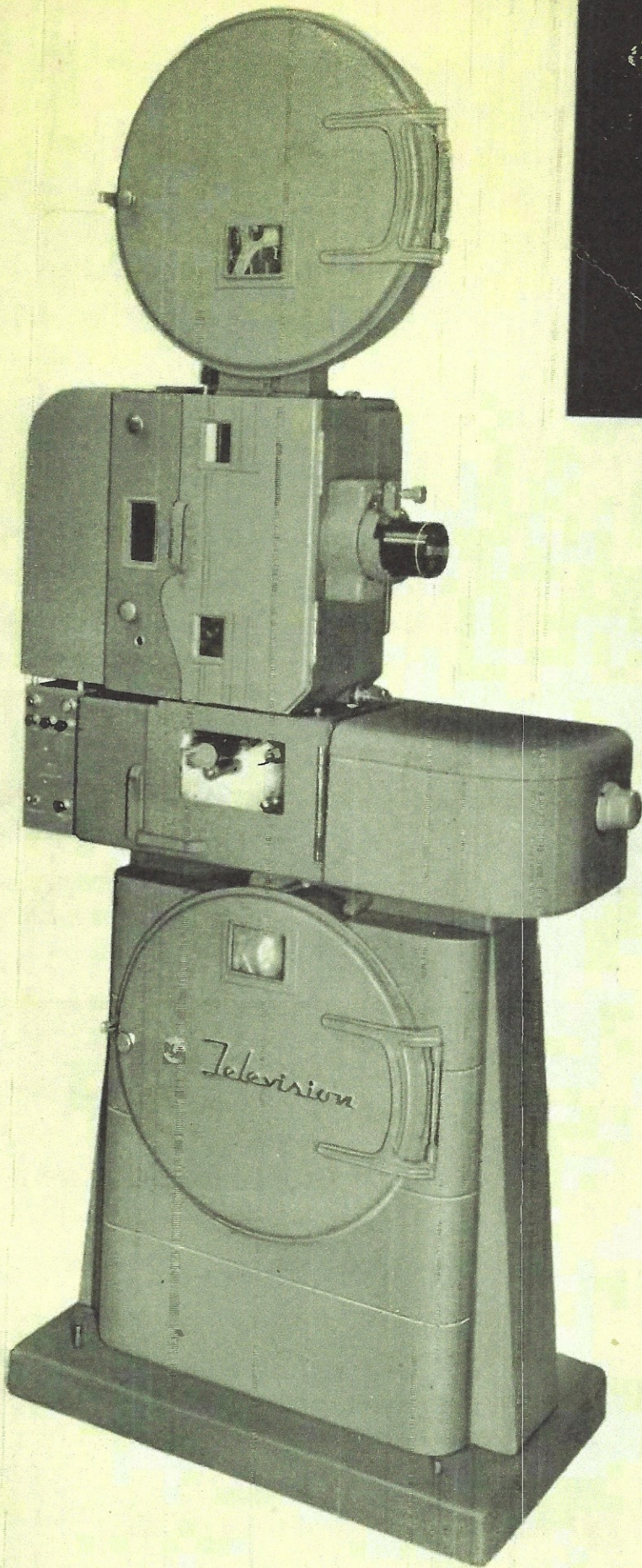

*"Electronic Television
is an RCA Development"*

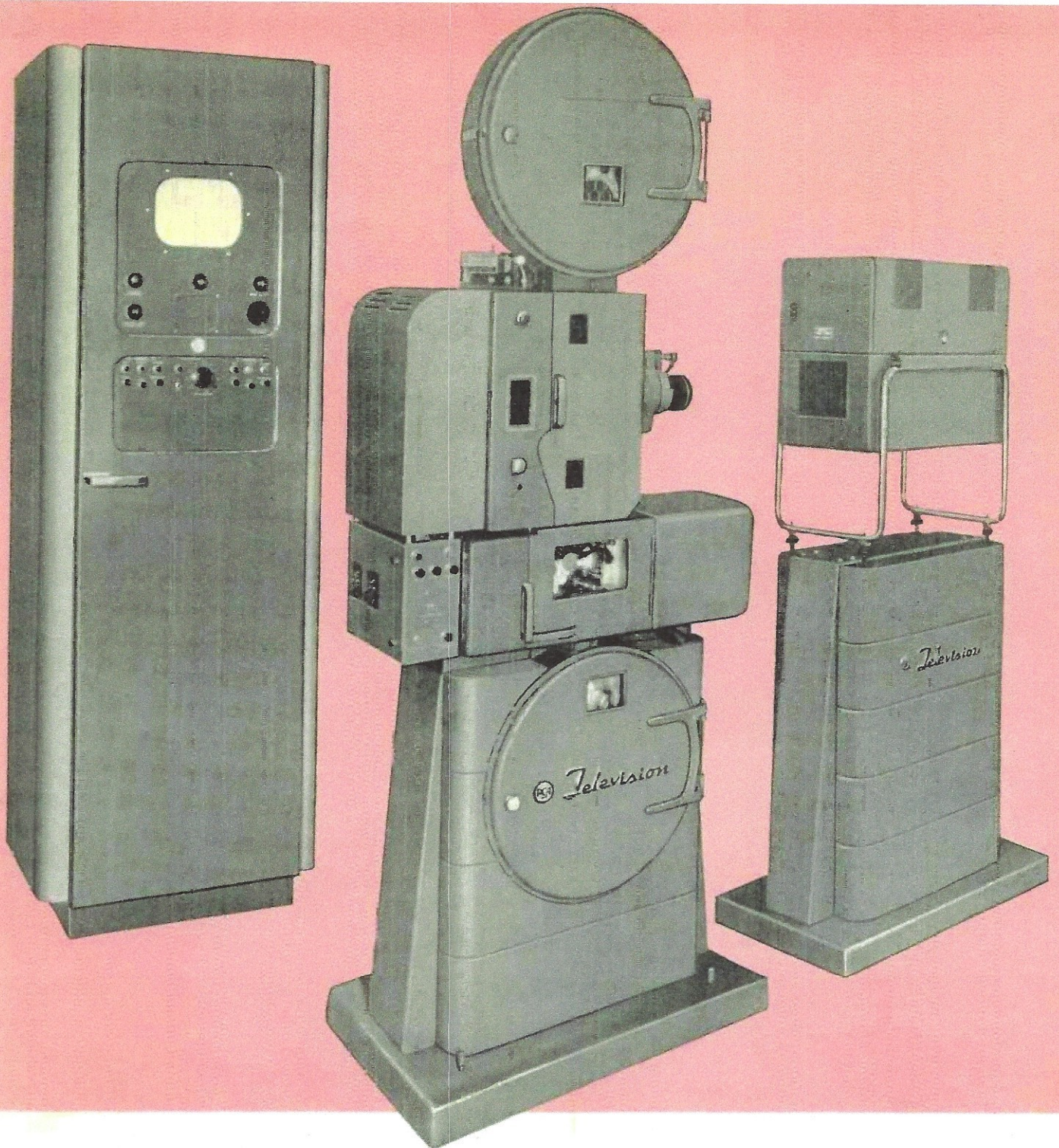

WHAT IT IS

The TP-35B Projector provides a convenient means for utilizing standard 35mm motion picture film as regular program material in television broadcasting stations. Film programs are the most economical of all television entertainment material. They may be alternated with "live" programs and network shows to add variety to the station's program schedule. The 35mm Film Projector permits the use of standard full-length feature film such as appear in motion picture theatres. In addition, numerous short subjects and newsreels are readily avail-

able on 35mm film and lend themselves well to television entertainment.

The TP-35B and its associated rack equipment are designed to meet the safety requirements of all states and local governments. Station owners are advised to consult local authorities for detailed regulations concerning projection room construction and equipment installation.

The TP-35B meets all RMA specifications and FCC requirements for television equipment.

HOW IT IS USED

The TP-35B Projector is designed for use in conjunction with the RCA Film Camera, Type TK-20A. This system is known as "direct projection" and is vastly superior to the "indirect" method wherein the picture is projected on a wall screen and picked up by the regular studio camera. The TP-35B projects the picture directly on the mosaic of the television pickup tube in the film camera. This arrangement assures much better contrast, resolution of detail, and freedom from flicker in the televising of moving pictures.

THE BASIC INSTALLATION

The complete TP-35B includes both the projector and the rack with its associated power supply monitor and control equipment. In the simplest arrangement, as in Fig. 1, the projector and camera are placed so as to face each other directly. This is a complete installation suitable for single reel programs. A single reel will carry a film of about twenty minutes duration. This is adequate for most film "shorts" and may be sufficient for many applications.

THE MULTIPLEXER AND SLIDE PROJECTOR

Fig. 2 illustrates a single projector and film camera used in conjunction with the RCA TP-9B Multiplexer. The Multiplexer is simply a pair of mirrors placed so as to reflect pictures from either one or two projectors into a single film camera. In addition there is surmounted on top a slide projector for the televising of slide stills. This arrangement provides for the projection of either single reel programs or slides and permits the easy addition of a second TP-35B film projector or a TP-16B 16mm projector at a later date.

THE TWO-PROJECTOR INSTALLATION

In Fig. 3 is shown the complete 35mm film projection installation for multi-reel programs as well as slide stills. The use of the Multiplexer makes it possible for a single film camera to serve for both projectors. When the first reel approaches the end, a changeover is made to the second projector. Both light and sound are switched instantaneously by pushing one button at the control rack.

A television station may start with the installation shown in Fig. 1 and expand its facilities as the need arises, or it may start initially with one of the more complete installations. In any case, this compact combination of projector, control rack, Multiplexer and film camera permits the greatest economy of investment and the minimum of required floor space.

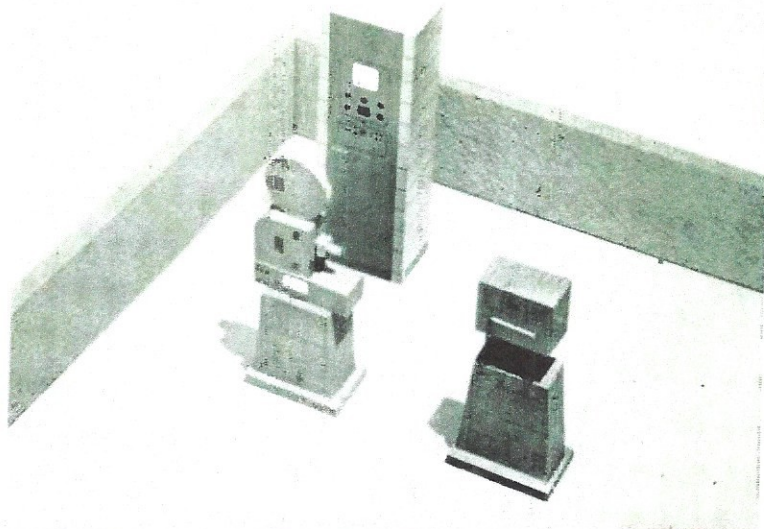

Fig. 1. The simplest arrangement

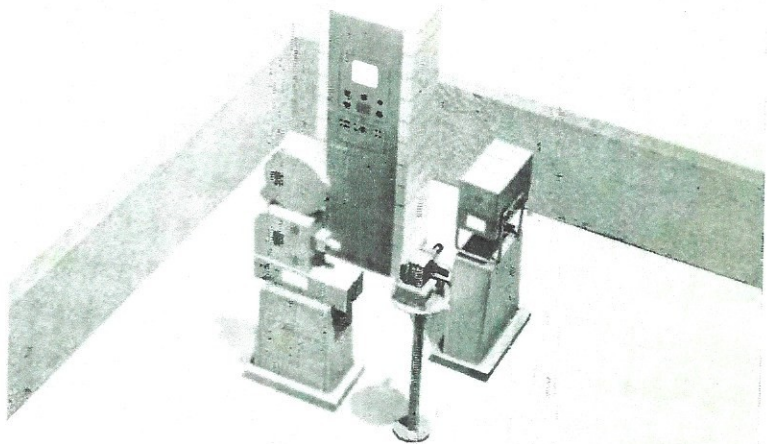

Fig. 2. . . . slide stills and room for expansion

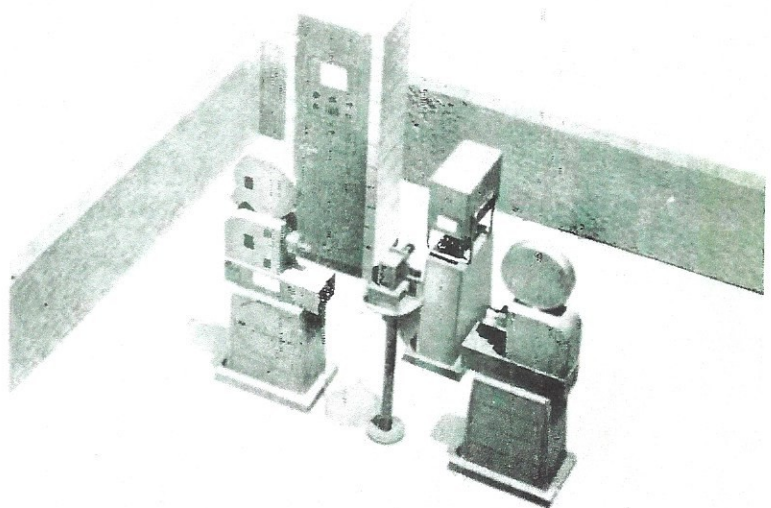
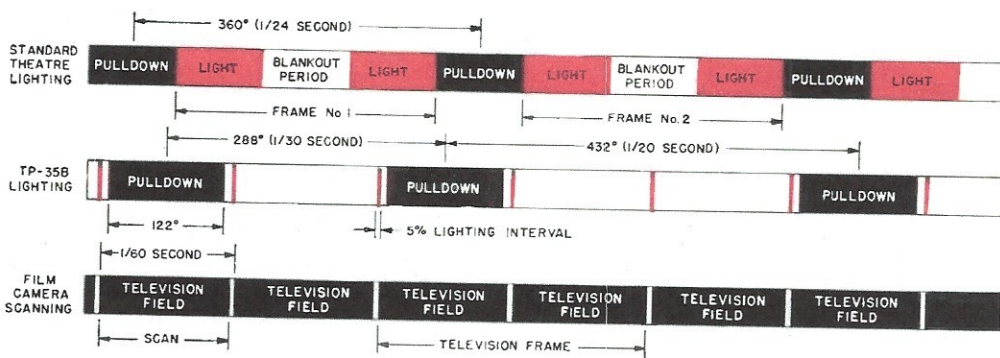
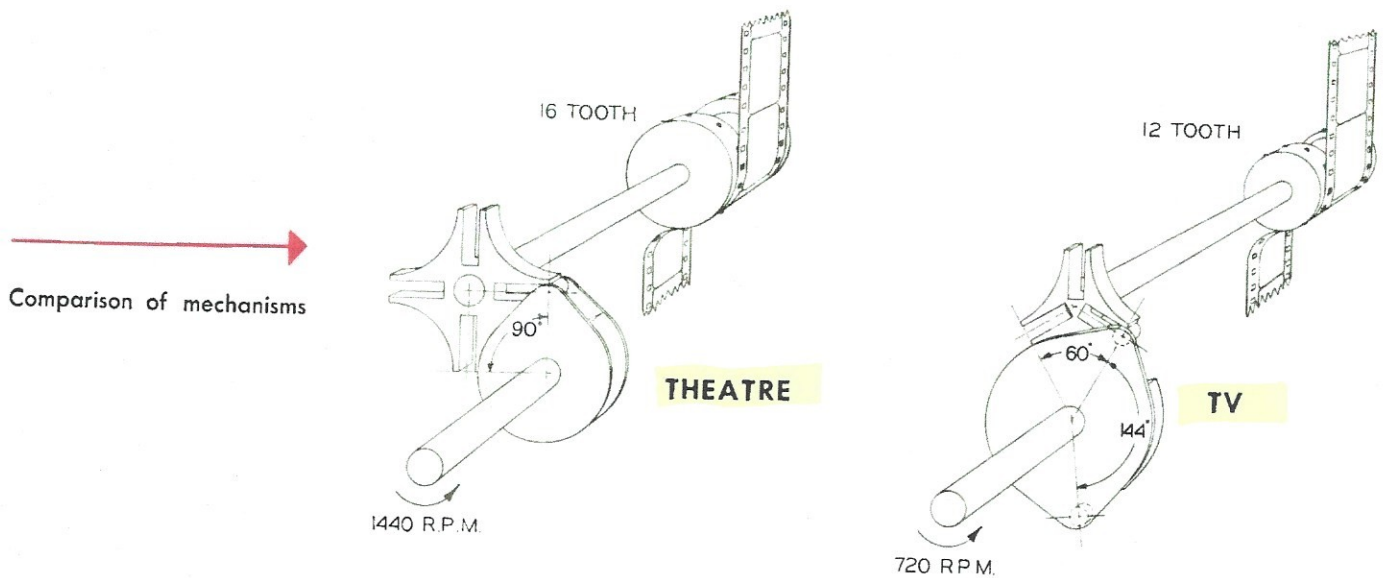

Fig. 3. Complete 35mm projection facilities

HOW THE TP-35B PERMITS THE USE OF STANDARD 35MM MOTION PICTURE FILM



Comparison of lighting

Since motion picture film is run at an average speed of 24 frames per second, and television standards require a basic rate of 30 frames per second, some means must be provided for conversion from the one rate to the other. In the TP-35B, this is accomplished by a specially designed intermittent. This intermittent is a three-sided geneva movement which, driven by a synchronous motor, pulls the film down at unequal time intervals. For example, alternate frames stay in place in the film gate (1/10 second) longer than the preceding frames. This together with speedy pull-down, allows the short duration (1/1200 second) light pulses, which flash regularly at 60 times per second, to flash twice through the first

frame, three times through the second, twice through the third, three times through the fourth and so on. Scanning in the pickup tube of the film camera is synchronized to follow the rate of the light pulses. It begins to scan immediately upon the cessation of each light flash, or during the unlighted intervals. Scanning during these unlighted intervals is possible because of the light-storage properties of the pickup tube. The scanning is interlaced 2 to 1 so that 60 fields and 30 complete frames are scanned per second, while the average speed of the film remains at 24 frames per second. The diagram above shows the true relationship between the framing, lighting and scanning sequences.

Pulse lighting runs cool, does not heat film or film-gate, obviates need for shutter.

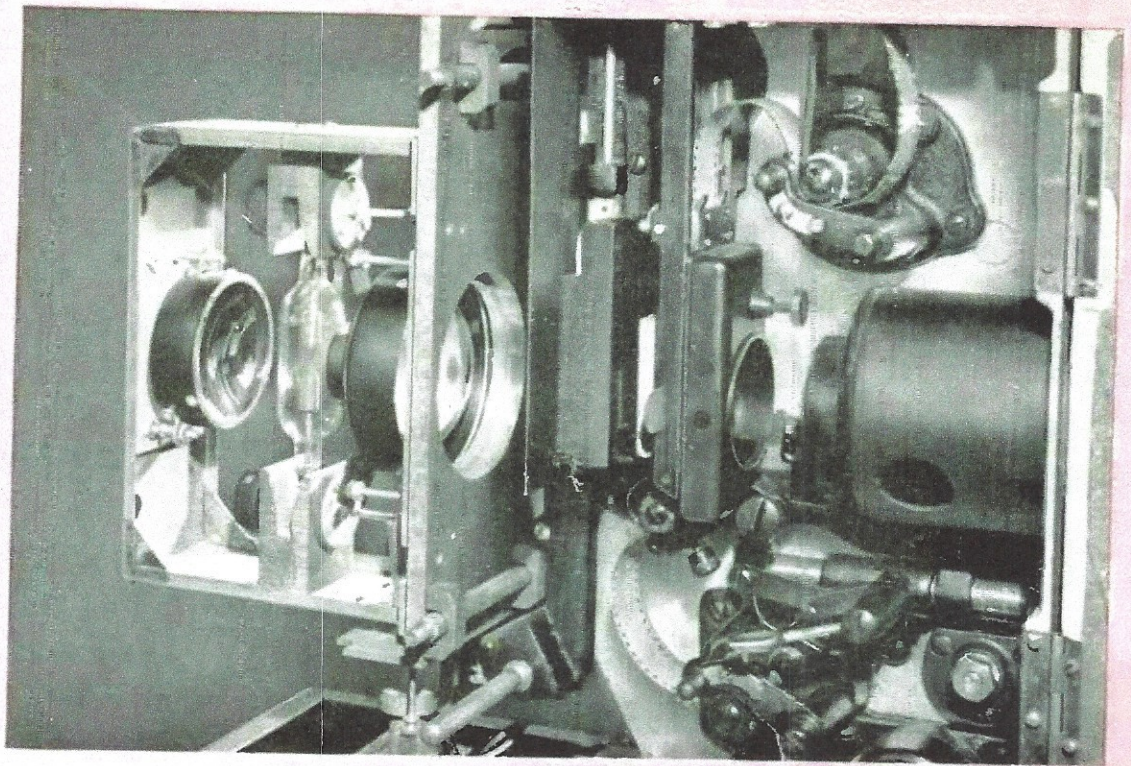

OPTICAL SYSTEM

The pulsed light source employed in the TP-35B provides adequate light output with negligible heating of the film or film gate. In addition, it obviates the need for a mechanical shutter mechanism. The low heating feature of the pulsed light source makes it possible to stop the film and project a single frame as a still. If this were done with conventional arc lighting, the extreme heat would destroy the film in very short order. The pulsed light source is provided from a gas-filled discharge tube driven by a pulsing power supply. The power supply is synchronized with the rest of the system

by the studio sync generator.

The optical system is adjusted at the factory so as to require a minimum of field servicing. The TP-35B uses the standard type of optical system used in film projectors. This system consists of a condenser lens system, and projection lens system. With the 6 1/2" focal length lens as furnished, the proper projection distance which gives the correct picture size is 48 3/4" from the film to the mosaic of the TK-20A iconoscope. A micrometer-type adjustment is provided for accurate setting of the projection lens barrel.

950-A Iconoscope

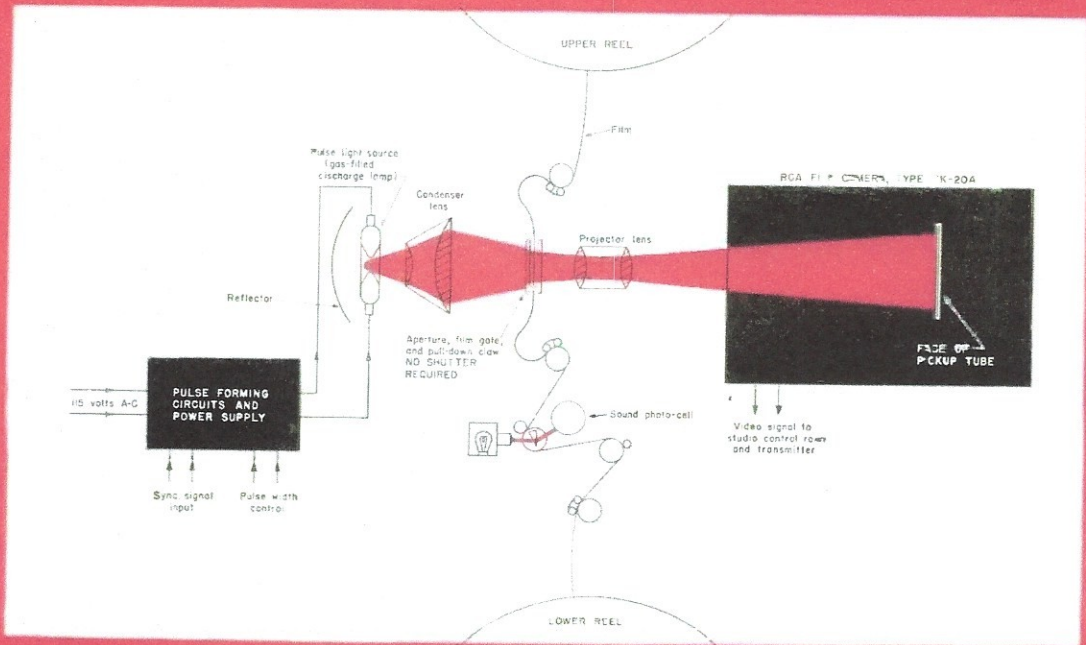

Simplified diagram showing picture and sound optical systems, film path, and operation of pulse light.

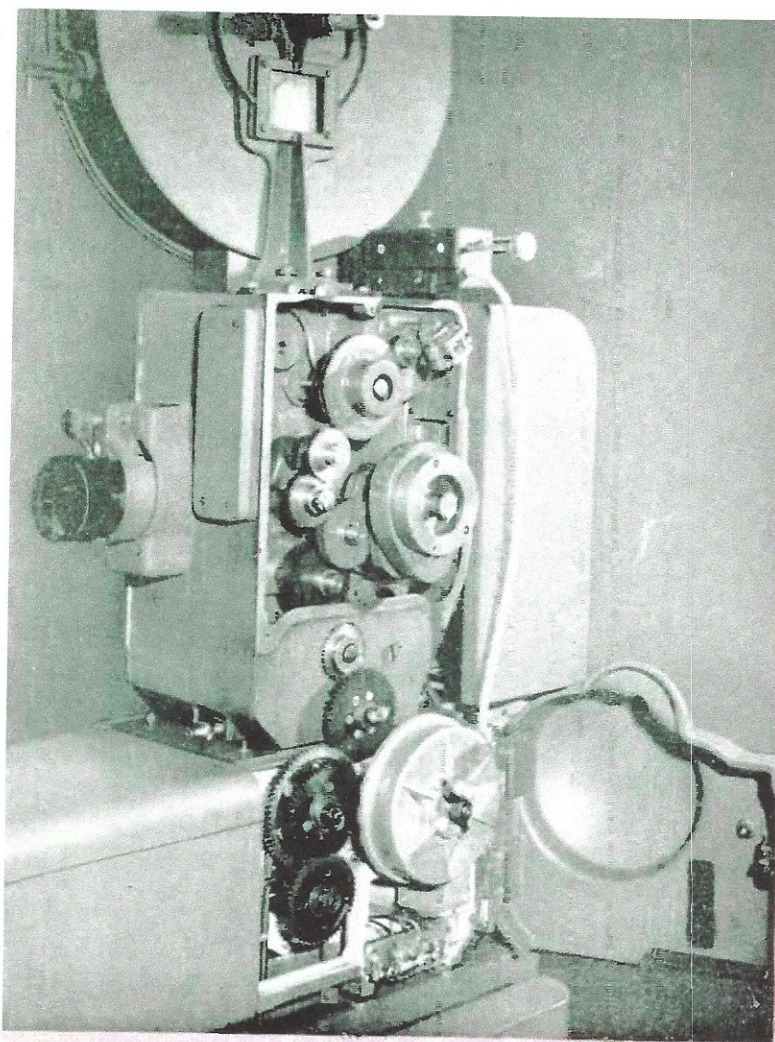

Constant oil bath on gears, close mechanical tolerances assure long, quiet operation.

the complete gear side of the projector, and screens the oil each time it passes through the intermittent mechanism and pump. All oil is completely sealed in, keeping dirt out of gears and bearings. The use of helical gears throughout contributes to the performance and long life of the projector. There are no angular-driven spiral gears with their necessary loose fitting and rapid wear.

The entire projector assembly is supported on a pedestal base which houses the lower film magazine and motor field power supply. The sound head is the standard RCA high quality unit used in all Brenkert theatre projectors. The pulse light power supply is mounted in the control rack in order to provide greatest convenience in service and operation, and in order not to add further to the bulk of the projector pedestal.

THE BRENKERT TP-35B EMERGENCY QUALITY SERVICE THREE MAINTENANCE

The TP-35B employs the most advanced features associated with film projection and its application to television programming. Mechanically, it is greatly simplified over earlier types of projectors. It is compact, attractively styled, and entirely functional.

The Brenkert-designed projector head makes use of much of the same high quality mechanism found in the Brenkert BX-80 Projector for theatre use. Close mechanical tolerances and automatic lubrication serve to produce an intermittent which will give long, trouble-free service. A combination pressure and splash lubrication system automatically circulates oil throughout

White interiors facilitate operation and service.

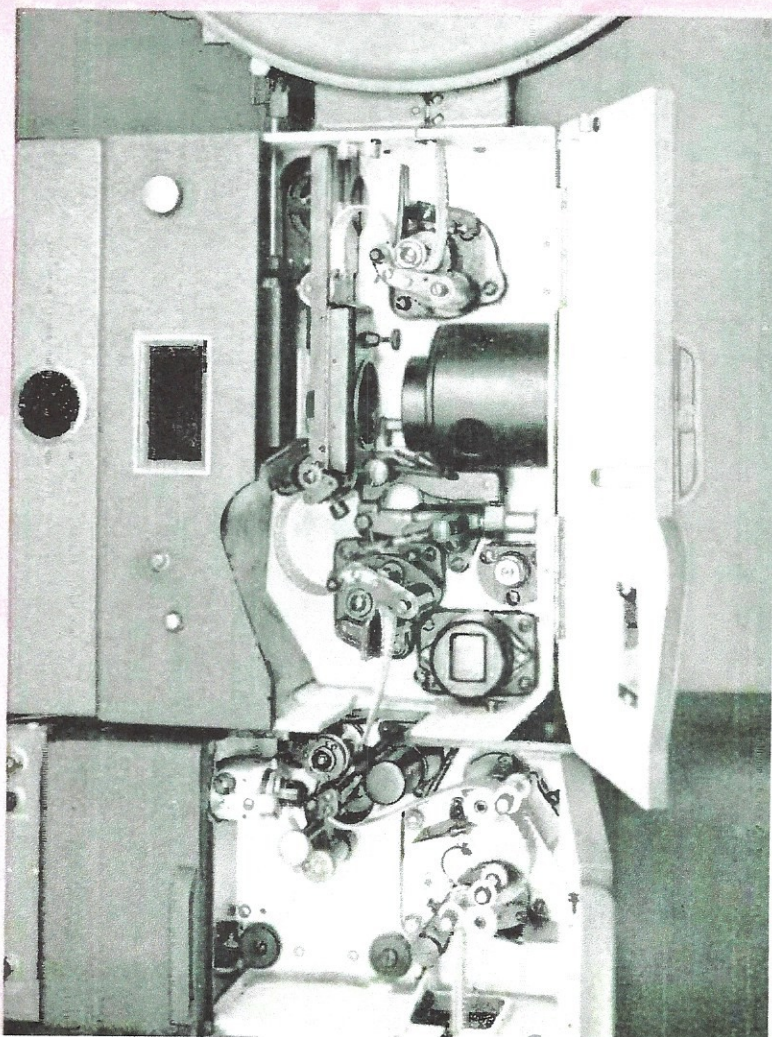



← Convenient local-control switch-box is located on projector.

→ A single button on the rack instantaneously switches both picture and sound.

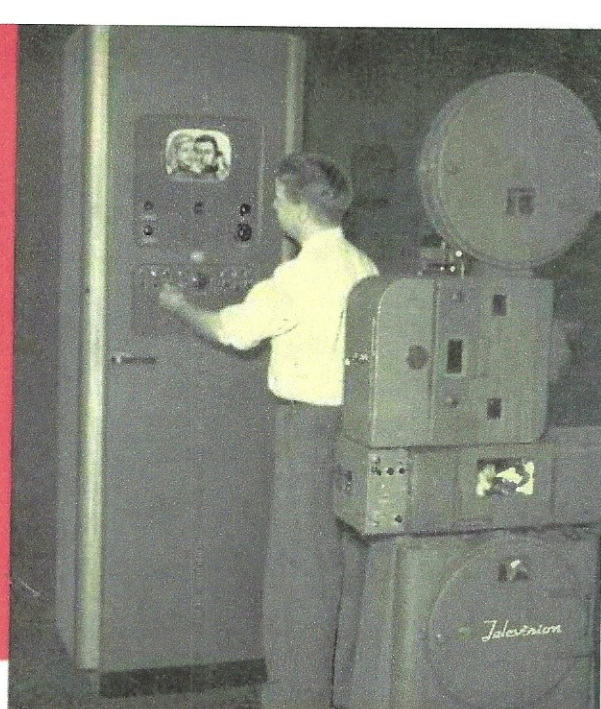

SINGLE CONTROL SWITCHING FROM CONTROL RACK MEANS GREATER CONVENIENCE AND EASE OF OPERATION

Auxiliary equipment, which is not part of the basic projector assembly is housed in a standard cabinet rack located in the room with the projector.

The rack equipment includes the power supply for the pulsed light system, an exciter lamp supply, a remote control panel, and a 10-inch picture monitor.

In addition, there is space for a second power supply or other auxiliary equipment. Controls on the projector and at the rack are such that the projector may be started and stopped either at the projector or at the equipment rack. Dousing and undousing operations which accom-

pany the changeover switching are accomplished by electrically-operated relays mounted on the projectors. In two-projector setups, both sound and picture switching are accomplished at the rack-mounted control panel. On the rack, mounted above the control panel, is the picture monitor which provides pictures for cueing the engineer in switching. When the first cue marks appear on the picture the engineer pushes the button to start the motor on the second projector. Upon the appearance of the second cue marks, the engineer pushes a single button which instantaneously switches both picture and sound from one to the other projector.

→ Installation at Station WENR-TV illustrates complete film projection facilities for both 16mm and 35mm film. Foreground projectors are RCA type TP-16B. TP-35B projectors are in background.

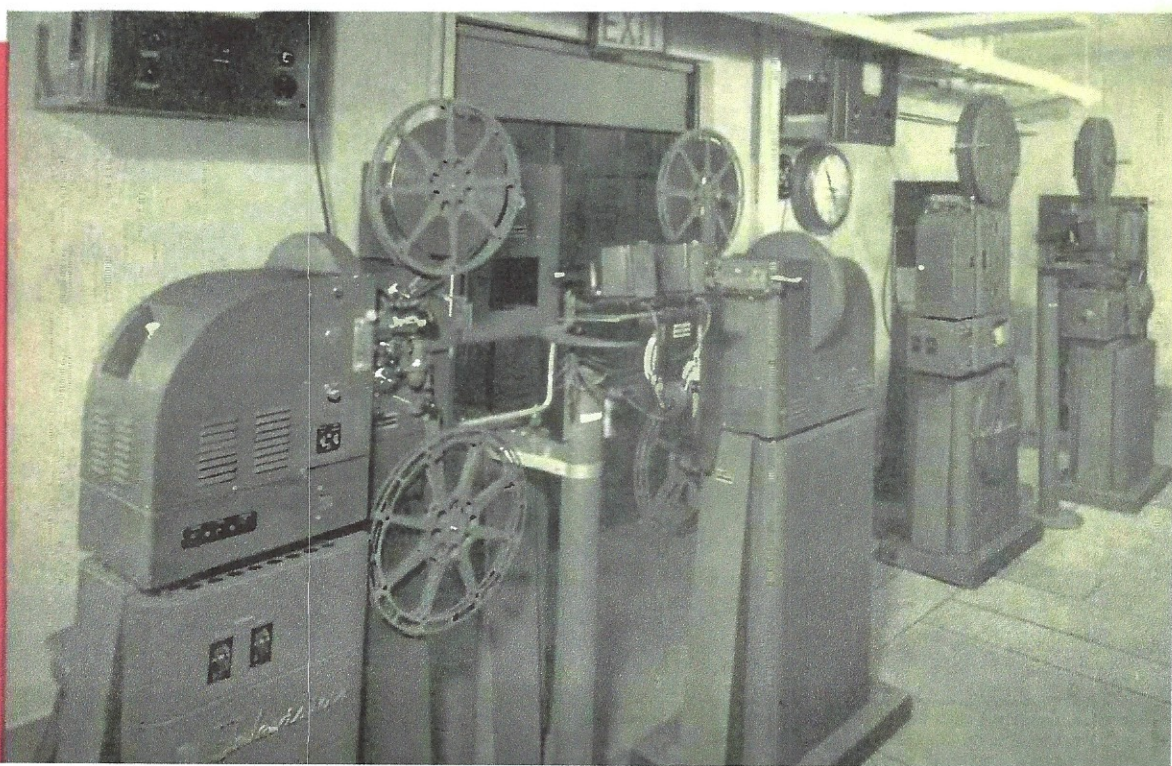

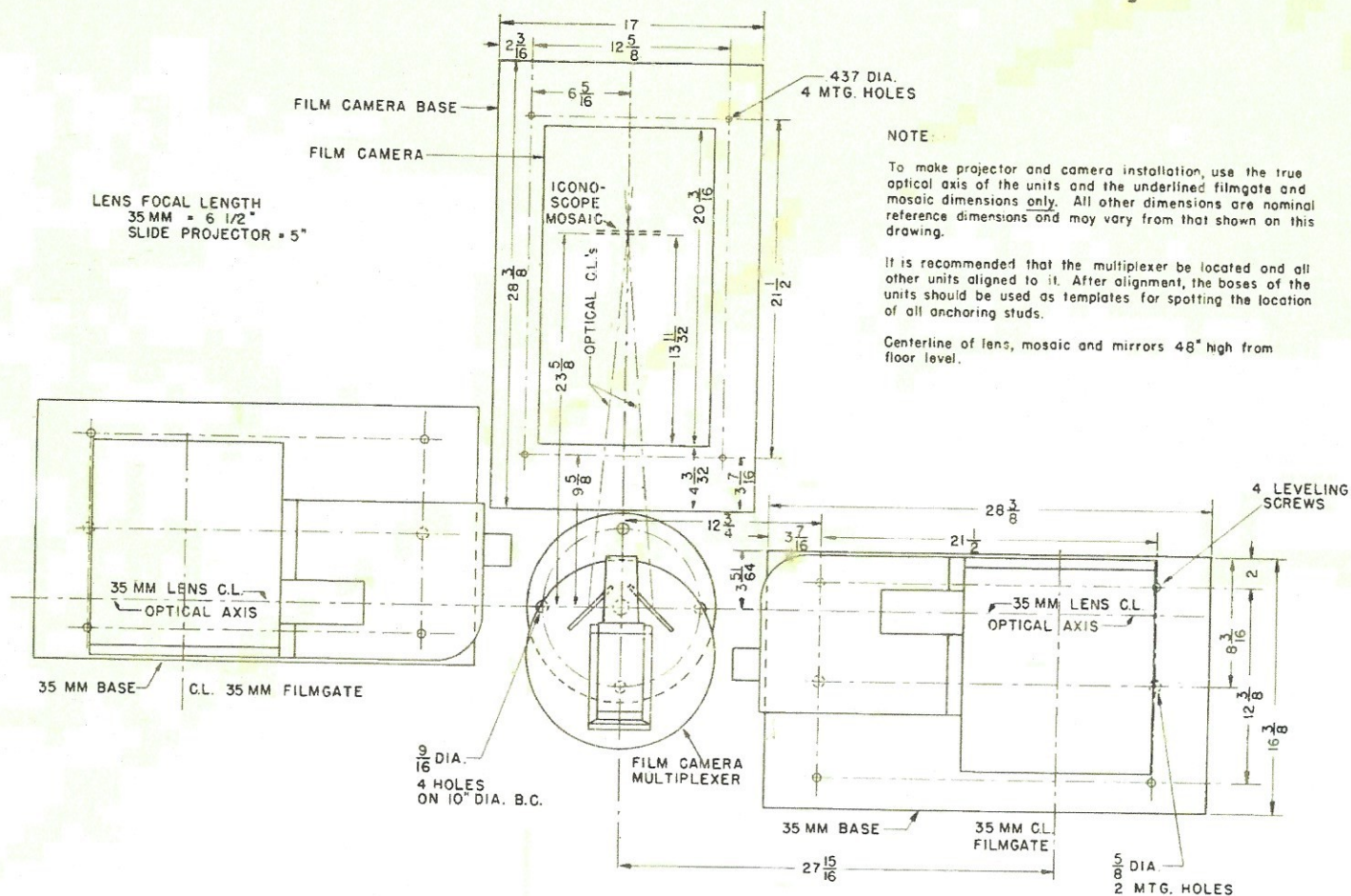

Mounting dimensions for complete two-projector installation. Light path dimensions indicated produce proper size picture on film camera mosaic when using $6\frac{1}{2}$ " projector lens.

SPECIFICATIONS

Film Type	Standard 35mm
Film Capacity	2000'
Film Speed	24 frames per second
Light Pulse	5% duration—60 times per second (synchronized with flyback time of camera pickup tube)
Projector Lens Line	48" above floor
Projection Distance ($6\frac{1}{2}$ " focal length lens)	48 $\frac{3}{4}$ "
Audio Output Impedance	500 ohms balanced
Dimensions (overall):	
Height	6' 3"
Width	16 $\frac{1}{2}$ "
Depth	34"

Weight	400 lbs. (approx.)
Power Requirements (Projector):	
Projector Motor	200 watts, 208 volts, three phase
Projector Motor Field Supply	100 watts, 115 volts, single phase
Pulsed Light Supply	2000 watts, 115 volts, single phase
Exciter Lamp Supply	15 watts, 115 volts, single phase
Tube Complement (for Projector only):	
	3—RCA 5U4G
	1—Exciter Lamp, 10v., 5 a.
	1—Type 868 Photo Cell (for Sound Head)

